

USER MANUAL

INTELLIGENT ADAS IA800

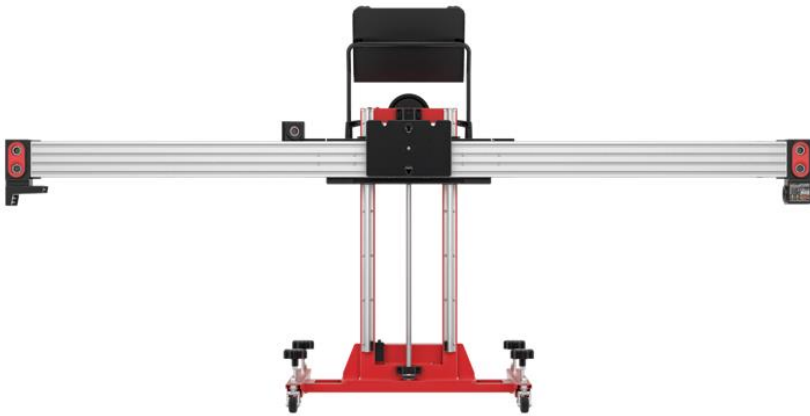

Trademarks

Autel® and MaxiSys® are trademarks of Autel Intelligent Technology Corp., Ltd., registered in China, the United States, and other countries. All other marks are trademarks or registered trademarks of their respective holders.

Copyright Information

No part of this manual may be reproduced, stored in a retrieval system or transmitted in any form or by any means electronic, mechanical, photocopying, recording, or otherwise without the prior written permission of Autel.

Disclaimer of Warranties and Limitation of Liabilities

All information, specifications and illustrations in this manual are based on the latest information available at the time of printing.

Autel reserves the right to make changes at any time without notice. While information of this manual has been carefully checked for accuracy, no guarantee is given for the completeness and correctness of the contents, including but not limited to the specifications, functions, and illustrations.

Autel will not be liable for any direct, special, incidental, or indirect damages, or for any economic consequential damages (including the loss of profits) as a result of using this equipment.

IMPORTANT

Before operating or maintaining this equipment, please read this manual carefully, paying extra attention to the safety warnings and precautions.

For Services and Support



pro.autel.com

www.autel.com



1-855-288-3587 (North America)

+86 (0755) 8614-7779 (China)



support@autel.com

For technical assistance in all other markets, please refer to *Technical Support* in this manual.

Safety Information

For your own safety and the safety of others, and to prevent damage to the equipment and vehicles upon which it is used, it is important that the safety instructions presented throughout this manual be read and understood by all persons operating or coming into contact with the equipment.

There are numerous procedures, techniques, tools, and parts required for servicing vehicles, as well as the skills of the person doing the work. Because of the vast number of test applications and variations in the products that can be tested with this equipment, we cannot possibly anticipate or provide advice or safety messages to cover every circumstance. It is the automotive technician's responsibility to be knowledgeable of the system being tested. It is crucial to use proper service methods and test procedures. It is essential to perform tests in an appropriate and acceptable manner that does not endanger your safety, the safety of others in the work area, the device being used, or the vehicle being tested.

Before using the equipment, always refer to and follow the safety messages and applicable test procedures provided by the manufacturer of the vehicle or equipment being tested. Use the equipment only as described in this manual. Be sure to read, understand, and follow all safety messages and instructions in this manual.

Safety Messages

Safety messages are provided to help prevent personal injury and equipment damage. All safety messages are introduced by a signal word indicating the hazard level.

DANGER

Indicates an imminently hazardous situation which, if not avoided, could result in death or serious injury to the operator or to bystanders.

WARNING

Indicates a potentially hazardous situation which, if not avoided, could result in death or serious injury to the operator or to bystanders.

Safety Instructions

The safety messages herein cover situations Autel is aware of at the time of publication. Autel cannot know, evaluate or advise you as to all of the possible hazards. You must be certain that any condition or service procedure encountered does not jeopardize your personal safety.

 **DANGER**

When an engine is operating, keep the service area WELL VENTILATED or attach a building exhaust removal system to the engine exhaust system. Engines produce carbon monoxide, an odorless, poisonous gas that causes slower reaction time and can lead to serious personal injury or loss of life.

 **It is not advised to use headphones at a high volume**

Listening at high volumes for long periods of time may result in loss of hearing.

 **Safety Warnings**

- Always perform automotive testing in a safe environment.
- Wear safety eye protection that meets ANSI standards.
- Keep clothing, hair, hands, tools, test equipment, etc. away from all moving or hot engine parts.
- Operate the vehicle in a well-ventilated work area, for exhaust gases are poisonous.
- Put the transmission in PARK (for automatic transmission) or NEUTRAL (for manual transmission) and make sure the parking brake is engaged.
- Put blocks in front of the drive wheels and never leave the vehicle unattended while testing.
- Be extra cautious when working around the ignition coil, distributor cap, ignition wires and spark plugs. These components create hazardous voltages when the engine is running.
- Keep a fire extinguisher suitable for gasoline, chemical, and electrical fires nearby.
- Do not connect or disconnect any test equipment while the ignition is on or the engine is running.
- Keep the test equipment dry, clean, free from oil, water or grease. Use a mild detergent on a clean cloth to clean the outside of the equipment as necessary.
- Do not drive the vehicle and operate the test equipment at the same time. Any distraction may cause an accident.
- Refer to the service manual for the vehicle being serviced and adhere to all diagnostic procedures and precautions. Failure to do so may result in personal injury or damage to the test equipment.
- To avoid damaging the test equipment or generating false data, make sure the vehicle battery is fully charged and the connection to the vehicle's DLC is clean and secure.
- Do not place the test equipment on the distributor of the vehicle. Strong electromagnetic interference can damage the equipment.

LASER RADIATION



Never point the laser beam at people, particularly at their face or eyes.

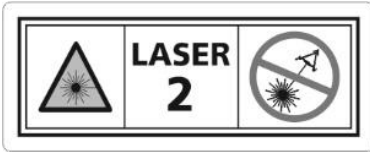

The term laser equipment refers to devices, systems or test set-ups generating, transmitting or employing laser radiation.

The class of the laser device indicates the level of potential danger associated with its accessible laser radiation. In the case of class 2 laser equipment, the accessible laser radiation is in the visible spectral range (400 nm to 700 nm).

The eyelids provide sufficient protection for inadvertent brief eye contact with such laser radiation. Class 2 laser devices may therefore be used without further precautionary measures if the user is definitely not required to either look into the laser intentionally for extended periods of time (>0.25 s) or repeatedly look into the laser or at directly reflected laser radiation.

WARNING

Taking medication or alcohol consumption will slow down the reflex action of the eyelids. This results in a particular risk. Wearing laser safety glasses of protection level R1 is recommended for anyone who is under the influence of medication.

Persons who are not trained to work with laser equipment and on the hazards of laser radiation, may not enter workplaces where work takes place with laser beams nor a laser emitting device.

Safety measures:

- The operator is to place the warning “Warning of Laser beam” at eye level and in a visible manner at the measuring station.
- Do not look directly into laser source.
- The operator must comply with the intended use.

INFRARED RADIATION



Infrared device inside. Avoid direct eye exposure.

Hot surface. Avoid contact directly.

Safety measures:

- The operator is to place the warning “Warning of Infrared Radiation” at eye level and in a visible manner at the measuring station.
- Do not look directly into IR source.
- The operator must comply with the intended use of the product.

WEAR SAFETY SHOES



Safety shoes must be worn.

When performing work with risk of injury to the feet, notice about the necessity of wearing protective shoes must be given. Foot injuries can, for example, be caused by falling over or falling tools or work items, trapping the foot, occurrence of nails or metal shavings in the soles, etc.

Safety measures:

- The operator is to place the mandatory sign “Wear Safety Shoes” at eye level and in a clearly visible manner at the measuring station.
- Operators should always wear the recommended protective shoes.

CONTENTS

1	USING THIS MANUAL	1
1.1	CONVENTIONS	1
1.1.1	Bold Text	1
1.1.2	Notes and Important Messages	1
1.1.3	Hyperlink	1
1.1.4	Illustrations	1
1.1.5	Procedures	2
2	GENERAL INTRODUCTION	3
2.1	FUNCTION DESCRIPTION	3
2.1.1	Camera kit (AUTEL-CSC0500/06)	3
2.1.2	Wheel Clamp (AUTEL-CSC0500/07)	5
2.1.3	Target (AUTEL-CSC0500/09)	6
2.1.4	Alignment Aid (AUTEL-CSC0500/08)	6
2.1.5	24V Power Adapter	7
2.1.6	Steering Wheel Holder Stand Tool (AUTEL-CSC0500/27)	7
2.1.7	Tablet Cradle	8
2.1.8	Wheel Chock	8
2.2	TECHNICAL SPECIFICATIONS	8
2.3	OTHER ACCESSORIES	9
3	ADAS CALIBRATION PROCEDURES	10
3.1	NIGHT VISION SYSTEM	10
3.1.1	Please select reason for calibration	10
3.1.2	Required Calibration Tools	11
3.1.3	Calibration Preparations	12

3.1.4	Auxiliary Tool Positioning	13
3.2	ADAPTIVE CRUISE CONTROL (ACC) SYSTEM.....	18
3.2.1	Please select reason for calibration	18
3.2.2	Required Calibration Tools.....	18
3.2.3	Calibration Preparations.....	19
3.2.4	Auxiliary Tool Positioning	20
3.3	LANE CHANGE ASSIST (LCA) SYSTEM	28
3.3.1	Please select reason for calibration	28
3.3.2	Required Calibration Tools.....	28
3.3.3	Calibration Preparations.....	29
3.3.4	Auxiliary Tool Positioning	30
3.4	LANE KEEP ASSIST (LKA) SYSTEM.....	35
3.4.1	Please select reason for calibration	35
3.4.2	Determine Vehicle Body Height	35
3.4.3	Required Calibration Tools.....	36
3.4.4	Calibration Preparations.....	37
3.4.5	Auxiliary Tool Positioning	38
3.5	AROUND VIEW MONITORING (AVM) SYSTEM.....	43
3.5.1	Please select reason for calibration	43
3.5.2	Required Calibration Tools.....	43
3.5.3	Calibration Preparations.....	43
3.5.4	Auxiliary Tool Positioning	44
4	ALIGNMENT PRECHECK PROCEDURES	52
4.1	ALIGNMENT PRECHECK.....	52
4.1.1	When Alignment Precheck is needed	52
4.1.2	Required Tools.....	53

4.1.3	Vehicle Preparations.....	53
4.1.4	Auxiliary Tool Positioning.....	54
5	MAINTENANCE AND SERVICE.....	57
5.1	MAINTENANCE INSTRUCTIONS.....	57
5.1.1	Target Maintenance.....	57
5.1.2	Camera Maintenance.....	57
5.2	SERVICE PROCEDURES.....	58
5.2.1	Technical Support.....	58
5.2.2	Repair Service.....	59
5.2.3	Other Services.....	60
6	COMPLIANCE INFORMATION.....	61

1 Using This Manual

This manual contains equipment usage instructions.

Some illustrations shown in this manual may contain modules and optional equipment that are not included in your system.

1.1 Conventions

The following conventions are used:

1.1.1 Bold Text

Bold text is used to highlight selectable items such as buttons and menu options.

Example:

- Tap **OK**.

1.1.2 Notes and Important Messages

Notes

A **NOTE** provides helpful information such as additional explanations, tips, and comments.

Important

IMPORTANT indicates a situation that if not avoided may result in damage to the equipment or vehicle.

1.1.3 Hyperlink

Hyperlinks are available in electronic documents. Blue italic text indicates a selectable hyperlink; blue underlined text indicates a website link or an email address link.

1.1.4 Illustrations

Illustrations used in this manual are samples; the actual testing screen may vary for each vehicle being tested. Observe the menu titles and on-screen instructions to make correct

option selection.

1.1.5 Procedures

An arrow icon indicates a procedure. Example:

➤ **To install the wheel clamps**

1. Check wheel clamp AUTEL-CSC0500/07-LR to ensure the four pawls (1) are equal in length.
2. Attach the two wheel clamps to the rear wheels respectively and rotate the bolt (2) clockwise until the pawls (1) are tightly secured.

2 General Introduction

The Autel MaxiSys Intelligent ADAS IA800 Camera & Adapter Kit is designed with six high-resolution cameras and ADAS positioning software to deliver rapid yet precise frame centering and vehicle distancing. The radar and camera used by the Lane Departure Warning, Lane Keeping Assist System, and Night Vision System necessitate the utmost precision when calibrating subsequent to most camera-related repairs. The IA800 displays vehicle-specific, step-by-step instructions and detailed illustrations to enable the technician to perform efficient, accurate calibrations on these increasingly popular vehicle systems.

The IA800 currently covers vehicles including Volvo, Volkswagen, Audi, Bentley, Volkswagen CV, Lamborghini, Seat, Skoda, FAW Audi, FAW Volkswagen, SAIC Volkswagen, SAIC Volkswagen Skoda, Porsche, Infiniti, Nissan, DF Nissan, DF Venucia, BMW MINI, BMW, BMW Brilliance, Rolls-Royce, Toyota, Lexus, Toyota China, Hyundai, Kia, BJ Hyundai, Dongfeng Yueda Kia, Honda, Acura, DF Honda, GZ Honda, Benz, Sprinter, Smart, Maybach, Ford, Ford EU, Ford China, Mazda, Mazda China, Chrysler, Dodge, Jeep, Peugeot, Citroen, DF Peugeot, DF Citroen, DS, Renault, Samsung, Land Rover, Jaguar, GM USA, GM China, Opel, Vauxhall, Fiat, Alfa, and Lancia.

2.1 Function Description

2.1.1 Camera kit (AUTEL-CSC0500/06)

NOTE

When facing the front of the ADAS main frame, the left camera unit is on the left side, the right camera unit is on the right side.

The left camera unit, featuring two cameras and four cables, is used to identify its designated target. Together with other cameras, the left camera unit can perform the ADAS calibration frame placement and four-wheel Alignment Precheck functions.

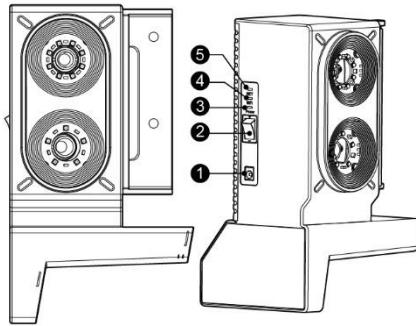

1. Power Port
2. Switch
3. Power Indicator
4. Wi-Fi Indicator
5. Internet Indicator

The center camera is used to identify its designated target. Together with other camera units, the center camera can perform the ADAS calibration frame placement and four-wheel Alignment Precheck functions.

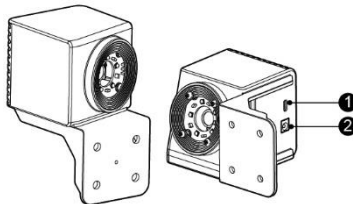

1. USB Port
2. Power Port

The right camera unit, featuring three cameras, is used to identify its designated target. Together with other cameras, the right camera unit can perform the ADAS calibration frame placement and four-wheel Alignment Precheck functions.

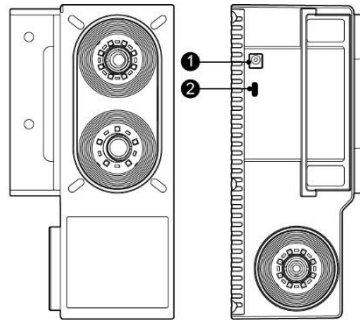

1. Power Port
2. USB Port

2.1.2 Wheel Clamp (AUTEL-CSC0500/07)

By vertically attaching to the wheel of the vehicle, the wheel clamp AUTEL-CSC0500/07 is used to hold the designated target AUTEL-CSC0500/09, so that the camera kit can identify it.

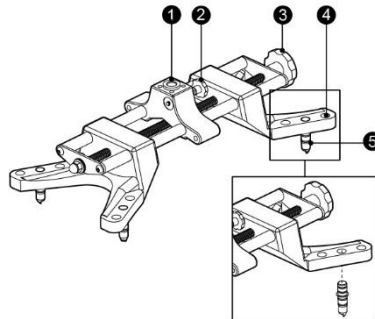

1. Fixing Axle Slot — for inserting the fixing axle of the target.
2. Tightening Screw — for tightening the fixing axle slot.
3. Tightening Screw — for tightening the wheel clamp onto the wheel.
4. Pawl Slots — for adjusting the pawls for different size of wheels.
5. Pawls — for attaching the wheel clamp to the wheel.

2.1.3 Target (AUTEL-CSC0500/09)

The front targets are inserted into the left front wheel clamp and right front wheel clamp to accurately read the wheel positioning parameters.

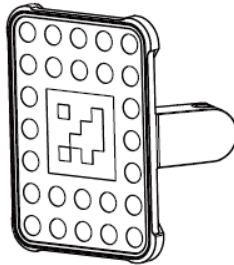

The rear targets are inserted into the left rear wheel clamp and right rear wheel clamp to accurately read the wheel positioning parameters.

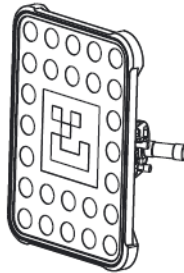

2.1.4 Alignment Aid (AUTEL-CSC0500/08)

The alignment aid is used to measure the distance from the calibration frame to each position of the vehicle body.

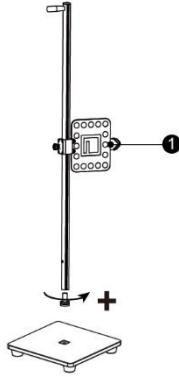

1. Distance Measuring Target

2.1.5 24V Power Adapter

The 24V power adapter is used to power the camera & adapter kit (AUTEL-CSC0500/06).

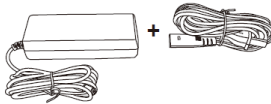

2.1.6 Steering Wheel Holder Stand Tool (AUTEL-CSC0500/27)

The steering wheel holder stand tool is used to fix the steering wheel position and align the vehicle.

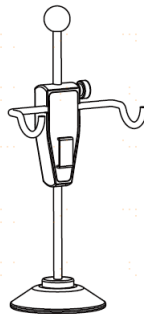

2.1.7 Tablet Cradle

The tablet cradle mounted to the calibration frame AUTEL-CSC0600 is used to hold the diagnostic tablet.

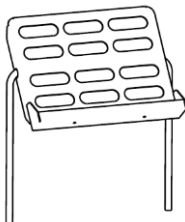

2.1.8 Wheel Chock

The wheel chock is used for chocking the wheel to prevent your vehicle rolling away.







2.2 Technical Specifications

Camera Specifications

Item	Description
Model	AUTEL-CSC0500/06
Connectivity	<ul style="list-style-type: none">● Wi-Fi● USB 2.0, Type C
Power Consumption	5 A @24 V
Operating Temp.	-10~50 °C
Storage Temp.	-20~60 °C
Dimension (W*H*D)	127.9 mm*220.7 mm*123 mm (Left Camera Unit) 75 mm*128.1 mm*92.5 mm (Center Camera) 113 mm*216.2 mm*92.5 mm (Right Camera Unit)

Item	Description
Net Weight	1375 g (Left Camera Unit)
	420 g (Center Camera)
	1140 g (Right Camera Unit)

2.3 Other Accessories

<p>Hex L-wrench (5 mm)</p> <p>1pc</p> 	<p>Sealing Strip</p> <p>1pc</p> 	<p>Bolt (M6x14)</p> <p>8pcs</p> 
<p>T Hammer Nut (M6)</p> <p>4pcs</p> 	<p>Sliding Nut (M6)</p> <p>4pcs</p> 	

3 ADAS Calibration Procedures

MaxiSys ADAS supports the calibration of cameras and sensors used by advanced driver-assistance systems (ADAS), including Adaptive Cruise Control (ACC), Blind Spot Detection (BSD), Rear View Camera (RVC), Lane Keep Assist (LKA), Around View Monitoring (AVM), and Night Vision System (NVS).

In this chapter, when the calibration is needed, what tools and preparatory measures are required and the toolset placement will be introduced using an Audi vehicle as an example. Because these methods vary slightly by vehicle, model and/or year, we have all the information included in the Set Up section of the tablet once you start the ADAS calibration session. Please follow the specific instructions in the Set Up section for the vehicle being serviced to ensure safe and accurate calibration.

The calibration toolset placement is followed by the calibration procedure, during which the MaxiSys tablet communicates with the vehicle ECU to complete the calibration. As the calibration procedure also varies by vehicle and model, please follow the step-by-step instruction on the MaxiSys tablet to complete the calibration.

3.1 Night Vision System

This instruction example uses an Audi vehicle.

Calibration procedures can vary by vehicle. Please follow the specific instructions on your tablet.

3.1.1 Please select reason for calibration

1. Repaired or replaced the Night Vision System (NVS) camera
2. Repaired or replaced the bumper or radiator grill
3. Adjusted the chassis
4. Changed the vehicle body height
5. Changed the position of NVS camera on the vehicle body

Select the accessory kit you purchased, tap A — the Camera Kit — on the tablet to proceed.

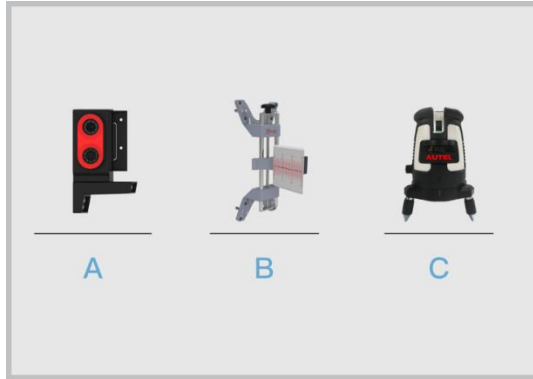

3.1.2 Required Calibration Tools

- ✓ Calibration Frame AUTEL-CSC0600
- ✓ NV Calibrator AUTEL-CSC0603/01
- ✓ Wheel Clamp AUTEL-CSC0500/07-LR
- ✓ Wheel Clamp AUTEL-CSC0500/07-RR
- ✓ Target AUTEL-CSC0500/09-LR
- ✓ Target AUTEL-CSC0500/09-RR
- ✓ Alignment Aid AUTE-CSC0500/08
- ✓ 12V Power Adapter
- ✓ 24V Power Adapter

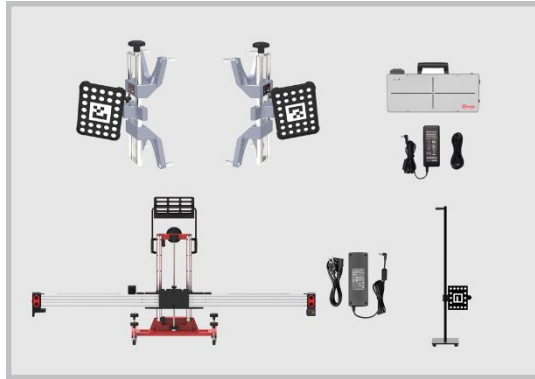

3.1.3 Calibration Preparations

1. Center the steering wheel and ensure that the front wheels of the vehicle are in a straight-ahead position (If necessary, perform the wheel alignment first);
2. Ensure the vehicle's coolant and engine oil are topped off and the gas tank is full. The vehicle should not be carrying any additional load (such as passengers or cargo);
3. Attach the VCI to the vehicle and connect the diagnostic tool to the VCI (if the diagnostic tool and VCI are connected by a diagnostic cable, guide the cable through a window);
4. Apply the parking brake, close all doors, and turn off all external lighting;
5. Adjust the tire pressure to the recommended level;
6. Keep the vehicle in a cold state;
7. If needed, connect the vehicle to a battery maintainer to prevent battery discharge;
8. Check that the Night Vision System (NVS) camera is inside the holder and that the view is unobstructed. (The NVS camera is generally located near the grill or the front emblem of the vehicle)
9. Check if the protective window of NVS camera is damaged. Replace if necessary.

NOTE

- Camera location may vary by vehicle.
- The calibration frame must be placed as stated before this calibration function can be performed.
- Tap **Set Up** to view set-up steps or tap **Video** to view a demonstration. After completing the set-up of the calibration frame and gathering the recommended tools, tap **OK** to start calibrating.
- Please refer to the Autel Calibration Tools User Manual to complete auxiliary tool positioning.

3.1.4 Auxiliary Tool Positioning

➤ To position the calibration frame and align the marked lines

1. Move the calibration frame to level ground in front of the vehicle. If the pattern board or the target board holder have been installed onto the crossbar, remove them first.
2. Rotate the fine tuning bolt (1) to align the red marked lines in point A.
3. Loosen the handle (2) and then rotate the fine tuning bolt (3) until the point B is aligned with the red marked line. Tighten the handle (2) to secure the crossbar.
4. Align the pointer on the sliding plate with the red marked line at point C, and then tighten the bolt (4) to secure the sliding plate.



➤ **To center the laser at the front of the vehicle**

1. Keep the front wheels of the vehicle in a straight-ahead position.
2. Place the calibration frame AUTEL-CSC0600 directly in front of the vehicle. Adjust the height of the crossbar to ensure it is roughly at the same height as the center of the front wheel.
3. Hold the handle on the calibration frame and slowly move the frame until the (horizontal) distances between the centers of both front wheels and the back of the crossbar are basically equal. The turn on the laser (1) and aim it at the front center of the vehicle.
4. Plug the included power cord into the power port (2) and turn on the power switch (3) of the camera group.

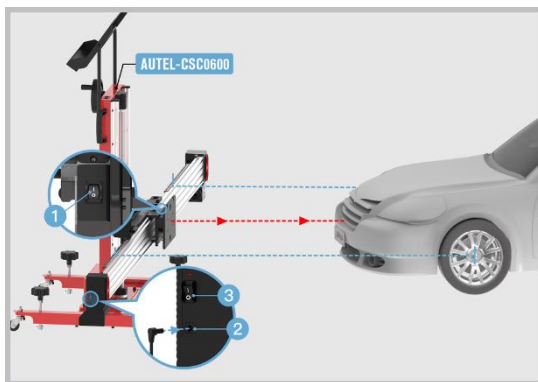

➤ **To install the wheel clamps**

1. Check wheel clamp AUTEL-CSC0500/07-LR to ensure the four pawls (1) are equal in length.
2. Attach the two wheel clamps to the rear wheels respectively and rotate the bolt (2) clockwise until the pawls (1) are tightly secured.

NOTE

Ensure wheel clamps are vertically installed on the hub, and that the installation angle is within the range of -8° and 8° .

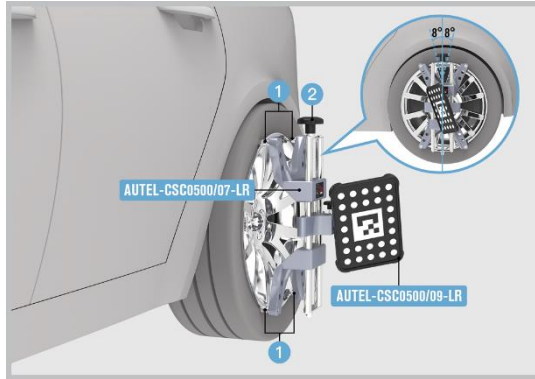

➤ **Placement of the distance measuring target**

1. Place the alignment aid AUTEL-CSC0500/08 in front of the vehicle. Loosen the bolt (1) to adjust the height of the target so that it is roughly at the same height as the center of the license plate. Then tighten the bolt (1) to secure the target.
2. Move the distance measuring target to ensure the pointer (2) of the target touches the license plate and is aimed at the center of the license plate as precise as possible. The white dotted side of the panel (3) should face the driving direction of the vehicle.

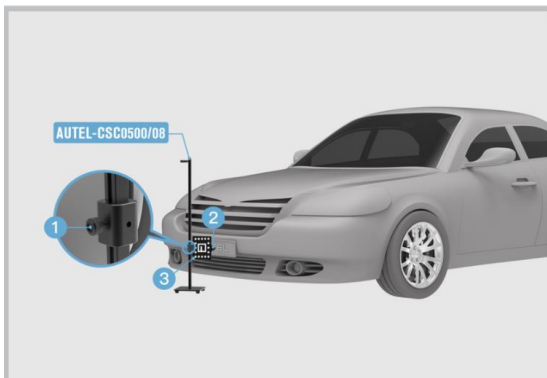

NOTE

- Check the calibration frame to make sure it has been properly positioned. Once positioned, click **OK** on the tablet to continue the calibration function.
- Do not perform the calibration function until the calibration frame is positioned properly. Click **Cancel** to return to the Preliminary Calibration Setup screen, where the steps for the placement of the calibration frame are demonstrated.

➤ **To install the NV calibrator**

1. Install the NV calibrator AUTEL-CSC0603/01 onto the crossbar sliding plate.
2. Rotate all the bolts (1) on the base so that the bubble in the bubble level (2) is centered.



3. Plug the included power cord into the power port (1). Turn on the power switch (2) and the red LED (3) will light up.

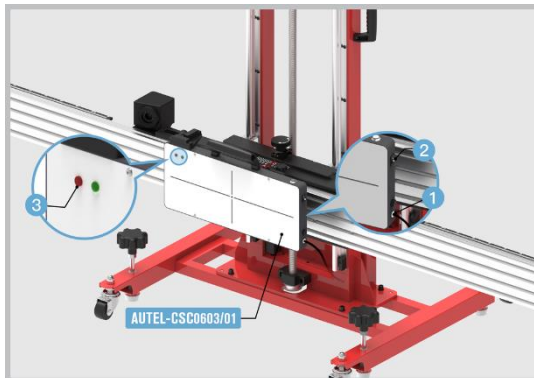

4. Turn on the laser (1).
5. Adjust the height of the crossbar and slide the NV calibrator AUTEL-CSC0603/01 left or right to aim the laser beam (2) at the center of the NVS camera.
6. Turn off the laser (1).

NOTE

If the bubble level shifts during adjustment, the horizontal position will need to be re-adjusted.

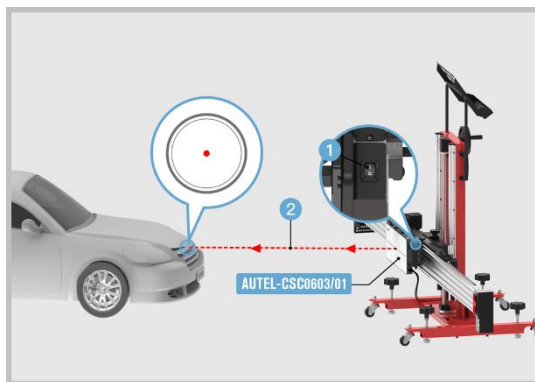

7. Press the button (1) for 2 seconds until the buzzer beeps intermittently.
8. After about 20 seconds, the green LED (2) will light.

NOTE

NV calibrator AUTEL-CSC0603/01 shuts off automatically after 30 minutes. The green LED turns off and the buzzer beeps for 1 second. Press the button (1) for 2 seconds to restart.

9. To turn NV calibrator OFF, press and hold the button (1) for 2 seconds.
10. Continue the next procedures until the calibration is successful.

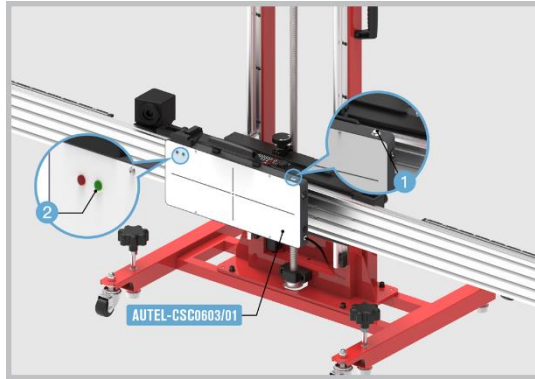

3.2 Adaptive Cruise Control (ACC) System

This instruction example uses an Audi vehicle.

Calibration procedures can vary by vehicle. Please follow the specific instructions on your tablet.

3.2.1 Please select reason for calibration

1. Repaired or replaced the Adaptive Cruise Control (ACC) radar sensor control unit
2. The ACC radar sensor deviation angle is out of normal range
3. Adjusted the position of the ACC radar sensor on the vehicle body
4. Repaired or replaced the bumper or radiator grill
5. Adjusted the chassis

Select the accessory kit you purchased, tap A — the Camera Kit — on the tablet to proceed.

3.2.2 Required Calibration Tools

- ✓ Calibration Frame AUTEL-CSC0600
- ✓ Reflector AUTEL-CSC0602/01
- ✓ Mini Reflector AUTEL-CSC0602/07
- ✓ Wheel Clamp AUTEL-CSC0500/07-LR

- ✓ Wheel Clamp AUTEL-CSC0500/07-RR
- ✓ Target AUTEL-CSC0500/09-LR
- ✓ Target AUTEL-CSC0500/09-RR
- ✓ Alignment Aid AUTEL-CSC0500/08
- ✓ 24V Power Adapter
- ✓ Hex Wrench AUTEL-CSC0602/06 or Other Tools for Radar Adjustment (not included)

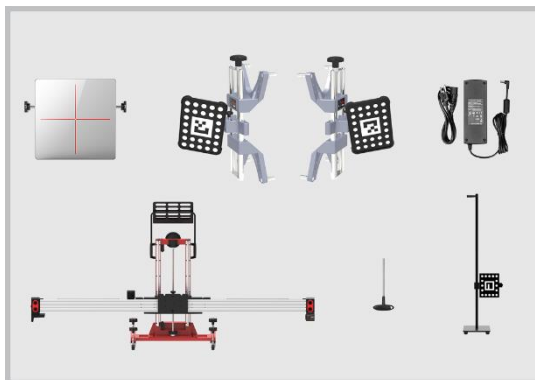

3.2.3 Calibration Preparations

NOTE

- Before calibration, check if the vehicle is equipped with Night Vision system.
- If night vision system is equipped, use the MaxiSys ADAS diagnostic tablet to check if calibration is needed. If calibration is needed, follow the night vision system calibration instructions on the tablet to complete calibration.
- After night vision system calibration is completed, the ACC radar sensor calibration can be performed with the same calibration frame (AUTEL-CSC0600) at the same position.
- If no night vision system is present or it does not need to be calibrated, perform ACC radar sensor calibration.

1. Park the vehicle on a level surface. Center the steering wheel and keep the front wheels of the vehicle in a straight position (If necessary, perform the wheel alignment first). Ensure there is a minimum space of 3 m in front of the vehicle;
2. Bring the vehicle to a complete stop, confirm the rear thrust angle is aligned and turn the ignition off;

3. Ensure the vehicle's coolant and engine oil are topped off and that the gas tank is full. The vehicle should not be carrying any additional load (such as passengers or cargo);
4. Attach the VCI to the vehicle and connect the diagnostic tool to the VCI (if the diagnostic tool and VCI are connected by a diagnostic cable, guide the cable through a window);
5. Close the vehicle doors and turn off all exterior lighting;
6. Adjust the tire pressure to the recommended level;
7. If needed, connect the vehicle to a battery maintainer to prevent battery discharge;
8. For vehicles with air suspension, activate "Jack Mode";
9. The ACC radar sensor is generally located on either side of the front bumper;
10. Remove the grill on the ACC radar sensor to check if the sensor is damaged or firmly attached. If it is damaged or not secure, repair or secure it.
11. Ensure the surface of the radar sensor is clean.

 **NOTE**

- The actual location of the sensor varies by vehicle.
 - The calibration frame must be properly positioned before this calibration function can be performed.
 - Tap **Set Up** to view set-up steps or tap **Video** to view a demonstration. After completing the set-up of the calibration frame and gathering the recommended tools and tap **OK** to start calibrating.
 - Refer to the Autel Calibration Tools User Manual to complete auxiliary tool positioning.
-

3.2.4 Auxiliary Tool Positioning

➤ **To position the calibration frame and align the marked lines**

1. Move the calibration frame to level ground in front of the vehicle. If the pattern board or the target board holder have been installed onto the crossbar, remove them first.
2. Rotate the fine tuning bolt (1) to align the red marked lines in point A.
3. Loosen the handle (2) and then rotate the fine tuning bolt (3) until the point B is aligned with the red marked line. Tighten the handle (2) to secure the crossbar.
4. Align the pointer on the sliding plate with the red marked line at point C, and then tighten the bolt (4) to secure the sliding plate.



➤ **To center the laser at the front of the vehicle**

1. Keep the front wheels of the vehicle in a straight-ahead position.
2. Place the calibration frame AUTEL-CSC0600 directly in front of the vehicle. Adjust the height of the crossbar to ensure it is roughly at the same height as the center of the front wheel.
3. Hold the handle on the calibration frame and slowly move the frame until the (horizontal) distances between the centers of both front wheels and the back of the crossbar are about equal. Turn on the laser (1) and aim it at the front center of the vehicle.
4. Plug the included power cord into the power port (2) and turn on the power switch (3) of the camera group.

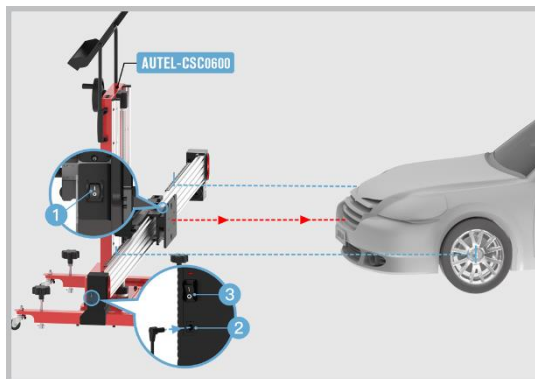

➤ **To install the wheel clamps**

1. Check the wheel clamp AUTEL-CSC0500/07-LR to ensure the four pawls (1) are equal in length.
2. Attach the two wheel clamps to the rear wheels respectively and rotate the bolt (2) clockwise until the pawls (Pos. 1) are tightly secured.

🔗 **NOTE**

Ensure wheel clamps are vertically installed on the hub and that the installation angle is within the range of -8° and 8° .

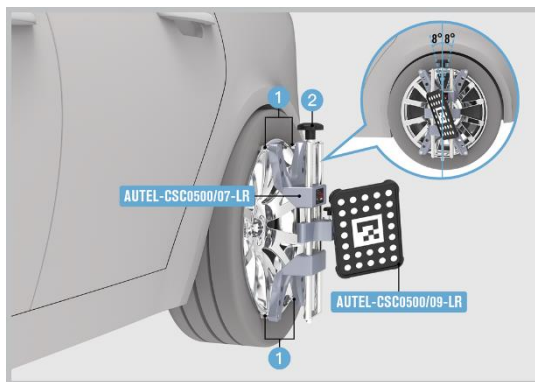

➤ **To place the distance measuring target**

1. Place the alignment aid AUTEL-CSC0500/08 in front of the vehicle. Loosen the bolt (1) to adjust the height of the target so that it is roughly at the same height as the center of the license plate. Then tighten the bolt (1) to secure the target.
2. Move the distance measuring target to ensure the pointer (2) of the target touches the license plate and is aimed at the center of the license plate as precisely as possible. The white dotted side of the panel (3) should face the driving direction of the vehicle.

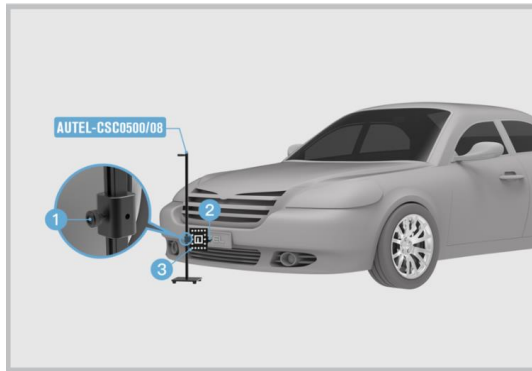

3. Please refer to the relevant information to enter the calibration distance from the front of the vehicle to the back of the crossbar (0.9 m–7.0 m).

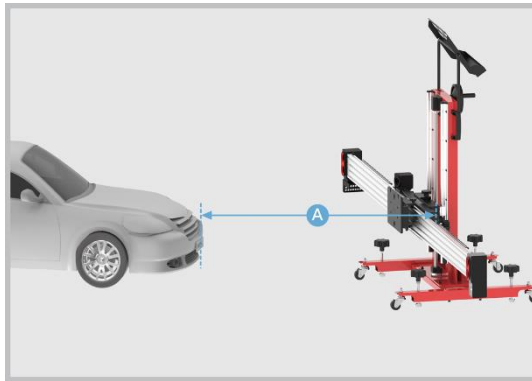

NOTE

- Check the calibration frame to make sure it has been properly placed. If it has been properly placed, click **OK** on the tablet to continue the calibration function.
 - Do not perform the calibration function until the calibration frame is placed properly. Click **Cancel** to return to the Preliminary Calibration Setup screen, where the steps for the placement of the calibration frame are demonstrated.
-

➤ **To install the reflector**

1. Fully attach the reflector AUTEK-CSC0602/01 to the crossbar sliding plate.
2. Rotate the bolt (1) on the reflector so that the side labeled "2" is facing up.

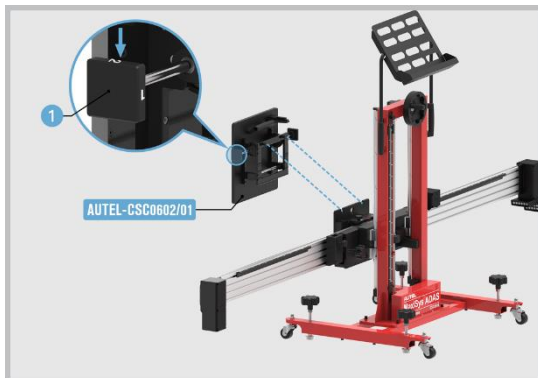

3. Rotate the bolt (1) on the base to ensure the bubble in the bubble level (2) is centered.



NOTE

To ensure diagnosis is conducted smoothly, please keep the diagnostic voltage higher than 12V. If voltage is insufficient, please connect the device to the battery charger.

4. Move the reflector AUTEK-CSC0602/01 left or right to aim the laser beam (2) at the mini reflector (3) on the radar sensor (on the right side of the vehicle's driving direction).

NOTE

- If the bubble in the bubble level deviates from the center during the adjustment, rotate the bolt on the base so that the bubble is centered.
- The location of the mini reflector may vary by vehicle.
- If there is no mini reflector, attach the mini reflector AUTEL-CSC0602/07 to any flat place on the radar surface and aim the laser beam at this mini reflector.

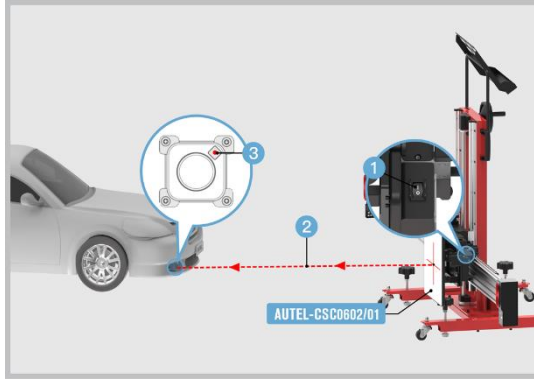

5. Use the hex wrench AUTEL-CSC0602/06 or other radar adjusters (not included) to adjust the sensor bolts (1 and 2) so that the reflected laser (3) aligns with its origin (4).

NOTE

The location of the adjustment bolt may vary by vehicle. Adjust the diagonal bolts until the reflected laser aligns with its origin.

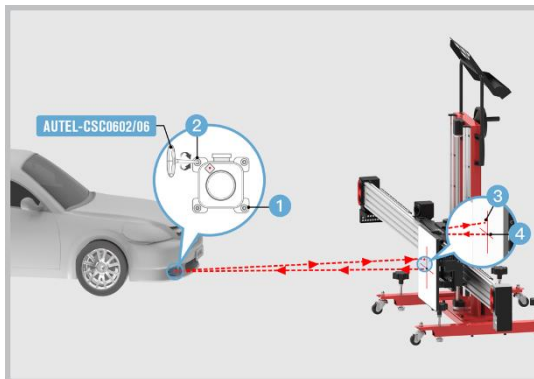

6. Adjust the ACC radar sensor on the left side of the vehicle in the same way.

➤ **Left ACC radar sensor calibration**

1. Turn on the sliding plate laser.
2. Adjust the height of the crossbar and move the reflector left or right to aim the laser beam at the center (1) of the radar sensor.
3. Turn off the sliding plate laser.

 **NOTE**

If the bubble in the bubble level deviates from the center during the adjustment, rotate the bolt on the base so that the bubble is centered.

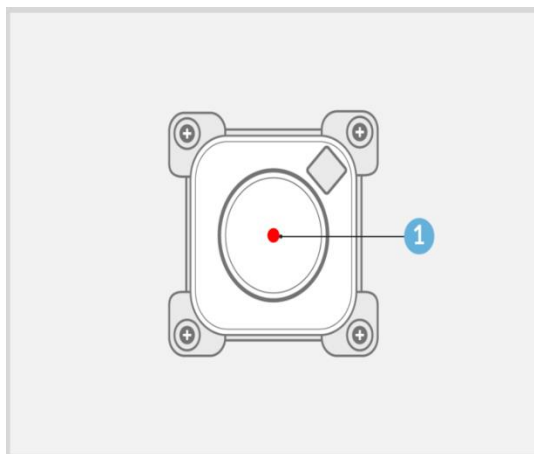

4. Rotate the knob A on the reflector AUTEL-CSC0602/01 so that the side labeled "1" is facing up.

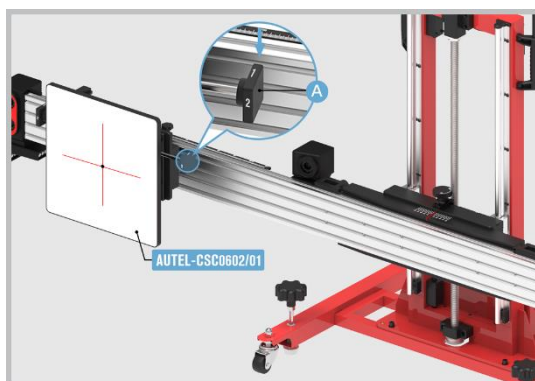

5. Rotate the knob A on the reflector AUTEL-CSC0602/01 so that the side labeled "2" is facing up.
6. Rotate the knob A on the reflector AUTEL-CSC0602/01 so that the side labeled 3 is facing up.
7. Ensure that the distance regulation control module-J428 (Master) is successfully adjusted. Finally, the distance regulation control module 2-J850 (Slave) is adjusted.
8. Turn on the laser (1).
9. Adjust the height of the crossbar and move the reflector AUTEL-CSC0602/01 left or right to aim the laser beam (2) at the mini reflector (3) on the radar sensor (on the right side of the vehicle's driving direction).

 **NOTE**

- If the bubble in the bubble level deviates from the center during the adjustment, rotate the bolt on the base so that the bubble is centered.
 - The location of the mini reflector may vary by vehicle.
 - If there is no mini reflector, attach the mini reflector AUTEL-CSC0602/07 on any flat place on the radar surface and aim the laser beam at the mini reflector.
-

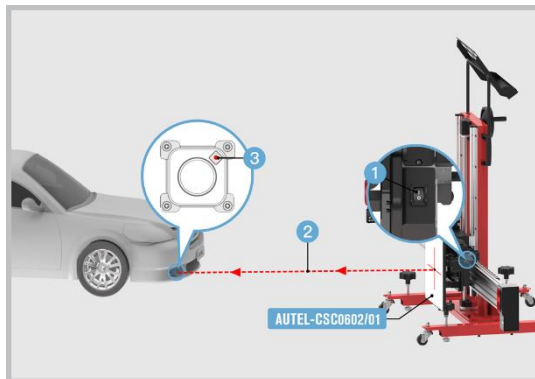

10. Use the hex wrench AUTEL-CSC0602/06 or other radar adjusters (not included) to adjust the sensor bolts (1 and 2) so that the reflected laser (3) aligns with the origin (4).

 **NOTE**

The location of the adjustment bolt may vary by vehicle. Adjust the diagonal bolts until the reflected laser aligns with its origin.

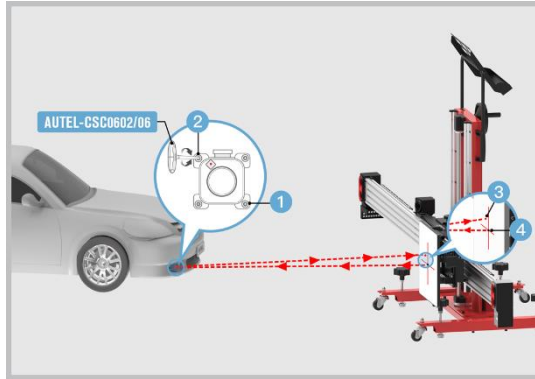

Calibrate the Right ACC radar sensor in the same way.

3.3 Lane Change Assist (LCA) System

This instruction example uses an Audi vehicle.

Calibration procedures can vary by vehicle. Please follow the instructions for your specific vehicle on your tablet.

3.3.1 Please select reason for calibration

1. Repaired or replaced the Lane Change Assist control unit
2. Repaired or replaced the rear bumper hood/trunk
3. Adjusted the position of Lane Change Assist control unit on the vehicle

Select the accessory kit you purchased, tap A — the Camera Kit — on the tablet to proceed.

3.3.2 Required Calibration Tools

- ✓ Calibration Frame AUTEL-CSC0600
- ✓ Radar Calibration Box AUTEL-CSC0605/01
- ✓ Wheel Clamp AUTEL-CSC0500/07-LR
- ✓ Wheel Clamp AUTEL-CSC0500/07-RR
- ✓ Target AUTEL-CSC0500/09-LR

- ✓ Target AUTEL-CSC0500/09-RR
- ✓ 24V Power Adapter (x2)



3.3.3 Calibration Preparations

1. Park the vehicle on a level surface. Center the steering wheel and keep the front wheels of the vehicle in a straight-ahead position (If necessary, perform the wheel alignment first). Ensure there is a minimum space of 4 m (158 in) x 4 m (158 in) behind the vehicle, measuring from the rear axle;
2. For vehicles with air suspension, set the chassis height to medium or automatic (shown on the instrument panel);
3. Ensure the vehicle's coolant and engine oil are topped off and the gas tank is full. The vehicle should not be carrying any additional load (such as passengers or cargo);
4. Attach the VCI to the vehicle and connect the diagnostic tool to the VCI (if the diagnostic tool and VCI are connected by a diagnostic cable, guide the cable through a window);
5. Apply the parking brake and close all doors. No one should be inside the vehicle;
6. Adjust the tire pressure to the recommended level;
7. If needed, remove the tinsel label on the bumper cover.

NOTE

- Do not open or close doors during calibration.
- The calibration frame must be positioned as stated before this calibration function can be performed.
- Tap **Set Up** to view set-up steps or tap **Video** to view a demonstration. After completing the set-up of the calibration frame and gathering the recommended tools, tap **OK** to start calibrating.
- Refer to the Autel Calibration Tools User Manual to complete auxiliary tool positioning.

3.3.4 Auxiliary Tool Positioning

➤ To position the calibration frame and align the marked lines

1. Move the calibration frame to level ground in front of the vehicle. If the pattern board or the target board holder have been installed onto the crossbar, remove them first.
2. Rotate the fine tuning bolt (1) to align the red marked lines in point A.
3. Loosen the handle (2) and then rotate the fine tuning bolt (3) until point B is aligned with the red marked line. Tighten the handle (2) to secure the crossbar.
4. Align the pointer on the sliding plate with the red marked line at point C, and then tighten the bolt (4) to secure the sliding plate.



➤ To center the laser behind the rear center of the vehicle

1. Place the calibration frame AUTEL-CSC0600 directly behind the rear center of the vehicle. Adjust the height of the crossbar to ensure it is roughly at the same height as the center of the rear wheel.
2. Hold the handle on the calibration frame and slowly move the frame until the

(horizontal) distances between the centers of both rear wheels and the back of the crossbar are about equal. Turn on the laser (1) and aim it at the rear center of the vehicle.

3. Plug the included power cord into the power port (2) and turn on the power (3) of the camera group.

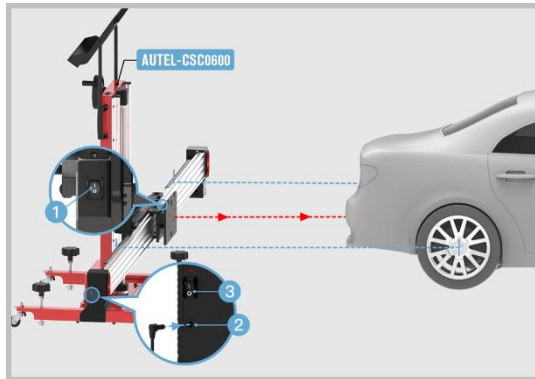

➤ **To install the wheel clamps**

1. Check the wheel clamp AUTEL-CSC0500/07-RR to ensure the four pawls (1) are equal in length.
2. Attach the left and right wheel clamps to their corresponding rear wheels, and rotate the bolt (2) clockwise until the pawls (1) are tightly secured.

NOTE

- The rear wheel target AUTEL-CSC0500/09-LR is installed on the right rear wheel and the rear wheel target AUTEL-CSC0500/09-RR is installed on the left rear wheel,
- Ensure wheel clamps are vertically installed on the hub and the installation angle is within the range of -8° and 8° .

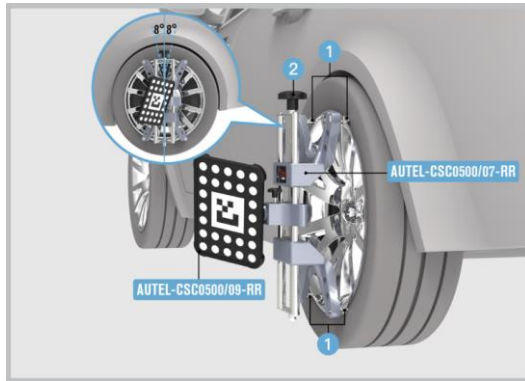

NOTE

- Check the calibration frame to make sure it has been properly positioned. If so, click **OK** on the tablet to continue the calibration function.
- Do not perform the calibration function until the calibration frame is positioned properly. Click **Cancel** to return to the Preliminary Calibration Setup screen where the steps for the positioning of the calibration frame are demonstrated.

To attach the radar calibration box

1. Fully attach the radar calibration box AUTEL-CSC0605/01 onto the sliding plate.
2. Rotate all the bolts (1) on the base of the calibration frame so that the bubble level (2) is centered.



3. Plug the included power cord into the power port (1). Turn on the switch (2) and the red LED (3) will light up. Do not go to the next step until approximately 10 seconds later when the green LED (4) lights up.

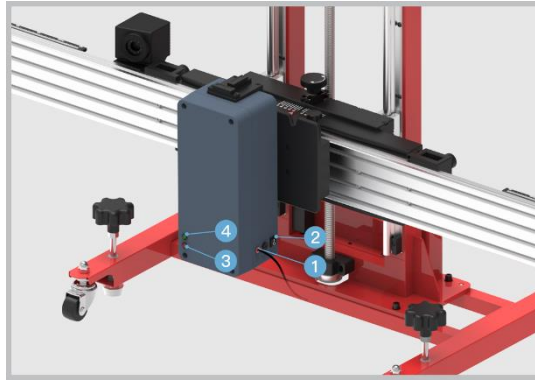

➤ **To adjust the crossbar height**

1. Loosen and pull the bolt at the top of the ruler (1) at the rear of the frame so that the ruler touches the ground.
2. Adjust the height of the crossbar (2) (manually by turning the crank wheel or by pressing the up or down buttons that engage the electric motor) to set the pointer (3) at 710 mm (27.95 in) on the A-side of the ruler.
3. Push the ruler (1) back to its original position and secure it.

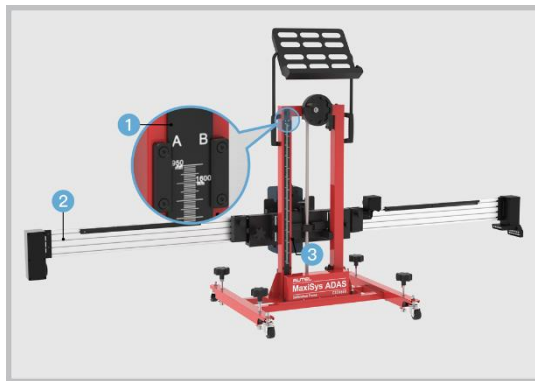

➤ **To calibrate the lane change assistant control units**

1. Move the radar calibration box AUTEL-CSC0605/01 to the vehicle's left side, and aim the marked line (1) on the pointer (on the back of the crossbar sliding plate) at b=710 mm (27.95 in) on the crossbar ruler.

NOTE

If the bubble in the bubble level deviates from the center during the adjustment, rotate the bolt on the base so that the bubble is centered.

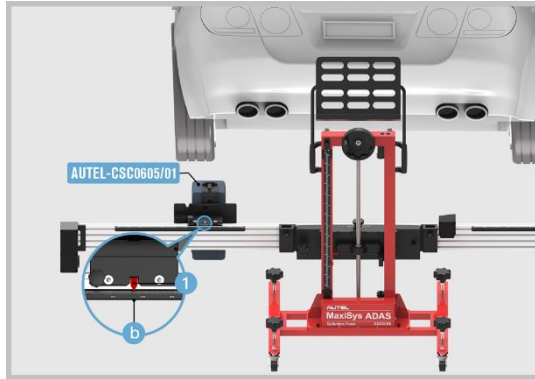

2. Follow the instructions displayed on the tablet until the calibration in one lane change assistant control unit is successful.
3. Move the radar calibration box AUTEL-CSC0605/01 to the vehicle's right side, and aim the marked line (1) on the pointer (on the back of the crossbar sliding plate) at b=700 mm (27.56 in) on the crossbar ruler.

NOTE

If the bubble in the bubble level deviates from the center during the adjustment, rotate the bolt on the base so that the bubble is centered.

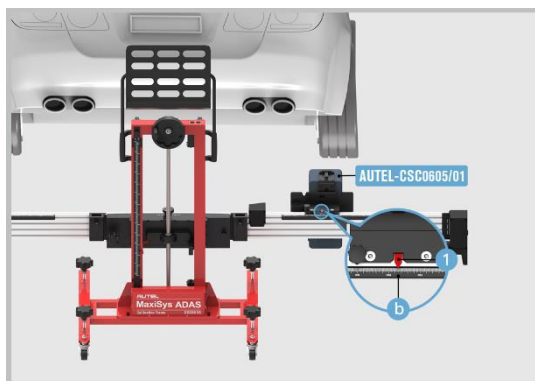

4. Please continue the next steps according to the tablet instructions until all the lane change assistant control units are successfully calibrated.

3.4 Lane Keep Assist (LKA) System

An Audi vehicle is used here to demonstrate frame setup and LKA system calibration.

Calibration procedures vary by vehicle. Please follow the instructions for your specific vehicle on your tablet.

3.4.1 Please select reason for calibration

1. Repaired or replaced the front video camera
2. Repaired or replaced the front windshield
3. Adjusted the chassis
4. Adjusted the vehicle body height
5. Relearned the vehicle height through vehicle height sensor

Select the accessory kit you purchased, tap A — the Camera Kit — on the tablet to proceed.

3.4.2 Determine Vehicle Body Height

Please choose a parking method:

1. If it's on level ground like figure A, choose Figure A;
2. If it's a spot (e.g. workshop station) where calibration frame and vehicle are not at the same level, choose Figure B.

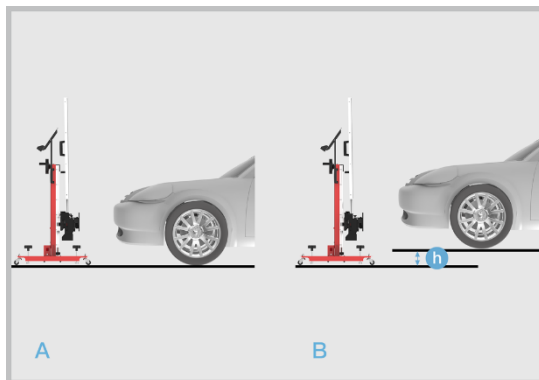

3. If Figure B is selected, measure the height gap h between the two levels and enter the measured value (unit: mm) on the tablet.

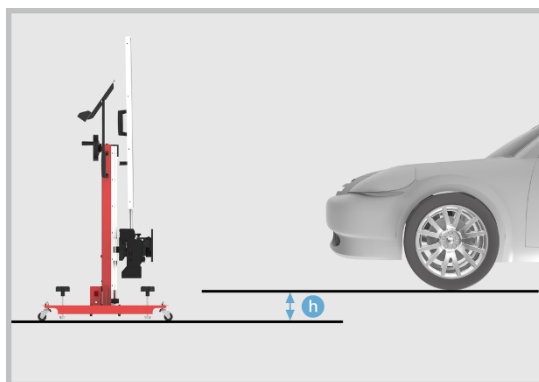

NOTE

If the vehicle body height is not in the adjustable range of the calibration frame, a warning message will appear. Proceed according to the message.

3.4.3 Required Calibration Tools

- ✓ Calibration Frame AUTEL-CSC0600
- ✓ Pattern Board AUTEL-CSC0601/01
- ✓ Wheel Clamp AUTEL-CSC0500/07-LR
- ✓ Wheel Clamp AUTEL-CSC0500/07-RR

- ✓ Target AUTEL-CSC0500/09-LR
- ✓ Target AUTEL-CSC0500/09-RR
- ✓ Alignment Aid AUTEL-CSC0500/08
- ✓ 24V Power Adapter

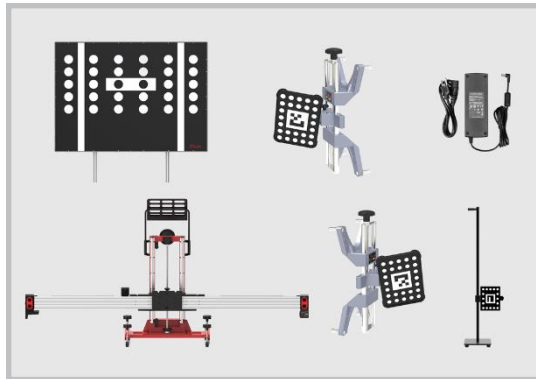

3.4.4 Calibration Preparations

1. Park the vehicle on a level surface. Center the steering wheel and keep the front wheels of the vehicle in a straight-ahead position (If necessary, perform the wheel alignment first);
2. Ensure there is at least 3 m of space in front of the vehicle;
3. Bring the vehicle to a complete stop, confirm the rear thrust angle is aligned and turn the ignition off;
4. Ensure the vehicle's coolant and engine oil are topped off and the gas tank is full. The vehicle should not be carrying any additional load (such as passengers or cargo);
5. Attach the VCI to the vehicle and connect the diagnostic tool to the VCI (if the diagnostic tool and VCI are connected by a diagnostic cable, guide the cable through a window);
6. Close all doors and turn off all exterior lighting;
7. Adjust the tire pressure to the specified level;
8. If needed, connect the vehicle to a battery maintainer to prevent battery discharge;

9. For vehicles with air suspension, activate the vehicle's jack mode;
10. Ensure the windshield and the camera lenses are clean, and that there are no obstacles blocking the camera's view;
11. Ensure the calibration area is well lit;
12. Clean and free the dashboard of any foreign objects than can cause glare on the windshield.

 **NOTE**

- Ensure there is no reflection on the windshield (reflective objects can be covered with a black cloth).
 - The calibration frame must be placed as stated before this calibration function can be performed.
 - Tap **Set Up** to view set-up steps or tap **Video** to view a demonstration. After completing the set-up of the calibration frame and gathering the recommended tools, tap **OK** to start calibrating.
 - Refer to the Autel Calibration Tools User Manual to complete auxiliary tool positioning.
-

3.4.5 Auxiliary Tool Positioning

➤ **To place the calibration frame and align the marked lines**

1. Move the calibration frame to level ground in front of the vehicle. If the pattern board or the target board holder have been installed onto the crossbar, remove them first.
2. Rotate the fine tuning bolt (1) to align the red marked lines in point A.
3. Loosen the handle (2) and then rotate the fine tuning bolt (3) until the point B is aligned with the red marked line. Tighten the handle (2) to secure the crossbar.
4. Align the pointer on the sliding plate with the red marked line at point C, and then tighten the bolt (4) to secure the sliding plate.



➤ **To center the laser at the front of the vehicle**

1. Keep the front wheels of the vehicle in a straight-ahead position.
2. Place the calibration frame AUTEL-CSC0600 directly in front of the vehicle. Adjust the height of the crossbar to ensure it is roughly at the same height as the center of the front wheel.
3. Hold the handle on the calibration frame and slowly move the frame until the (horizontal) distances between the centers of both front wheels and the back of the crossbar are about equal. Turn on the laser (1) and aim it at the front-center of the vehicle.
4. Plug the included power cord into the power port (2) and turn on the power (3) of the camera group.

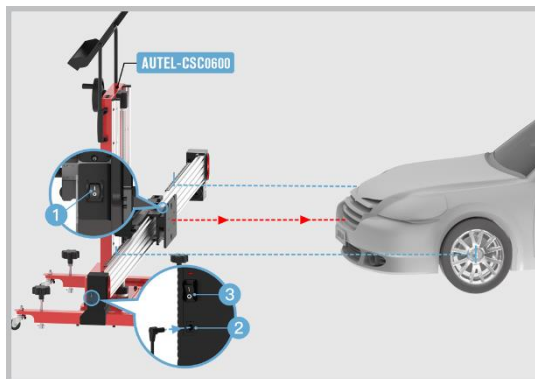

➤ **To install the wheel clamps**

1. Check the wheel clamp AUTEL-CSC0500/07-LR to ensure the four pawls (1) are equal in length.
2. Attach the two wheel clamps to the rear wheels respectively and rotate the bolt (2) clockwise until the pawls (1) are tightly secured.

 **NOTE**

Ensure wheel clamps are vertically installed on the hub and the installation angle is within the range of -8° and 8° .

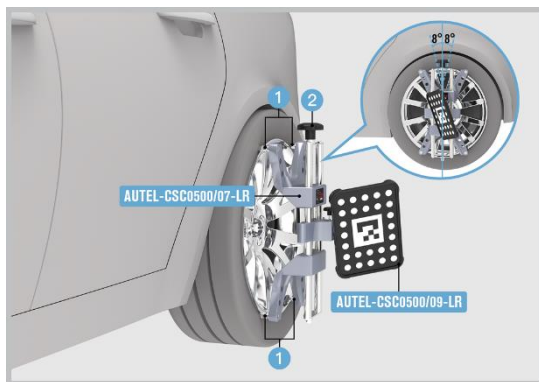

➤ **To place the distance measuring target**

1. Place the alignment aid AUTEL-CSC0500/08 near the center of the right front wheel of the vehicle (based on the driving direction of the vehicle). Loosen the bolt (1) to adjust the height of the target pointer (2) so that it is roughly at the same height as the center of the front wheel. Then tighten the bolt (1) to secure the target.
2. Move the distance measuring target to ensure the pointer (2) of the target is directly aimed at the center of the right front wheel. Meanwhile, the white dotted side of the panel (3) should face the driving direction of the vehicle.

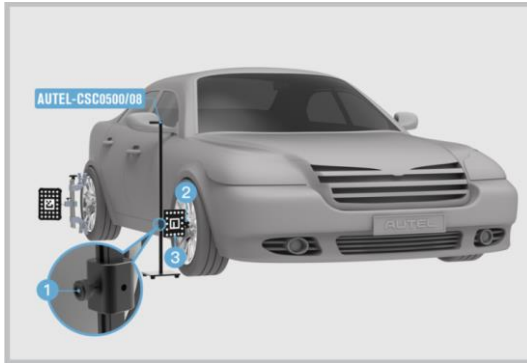

NOTE

- Check the calibration frame to make sure it has been properly positioned. If so, click **OK** on the tablet to continue the calibration function.
- Do not perform the calibration function until the calibration frame is placed properly. Click **Cancel** to return to the Preliminary Calibration Setup screen where the steps for the placement of the calibration frame are demonstrated.

➤ **To place the auxiliary tool**

1. Attach the pattern board AUTEL-CSC0601/01 onto the crossbar of the calibration frame (If using the target holder booster AUTEL-CSC0600/03, attach the pattern board to the target holder booster), and tighten the bolt (1) to secure it.

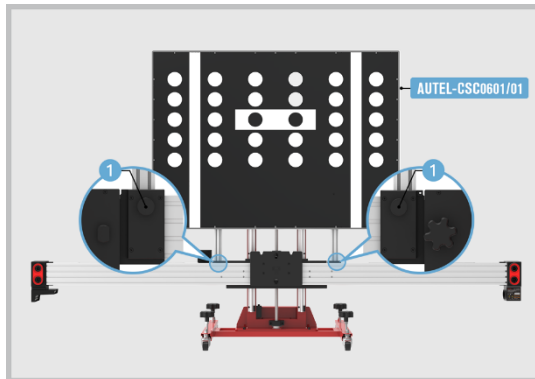

2. Rotate the bolt (1) on the base to ensure the bubble in the bubble level (2) is centered.

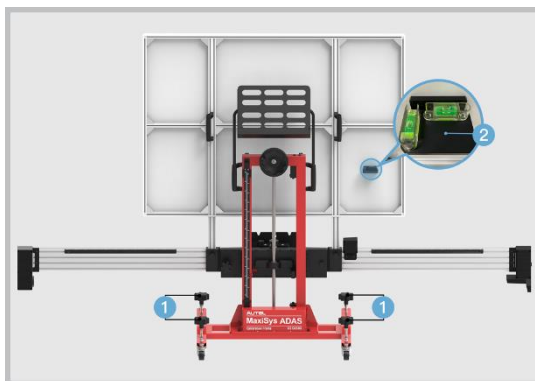

3. Loosen and pull the bolt at the top of the ruler (1) that is located in the rear of the frame so that the ruler touches the ground.
4. Adjust the height of the crossbar (2) (manually by turning the crank wheel or by pressing the "up" or "down" buttons that engage the electric motor) to set the pointer (3) at 1090 mm (42.91 in) on the B-side of the ruler (If using the target holder booster, set the pointer (3) at 740 mm (29.13 in) on the B-side of the ruler).
5. Push the ruler (1) back to its original position and secure it.

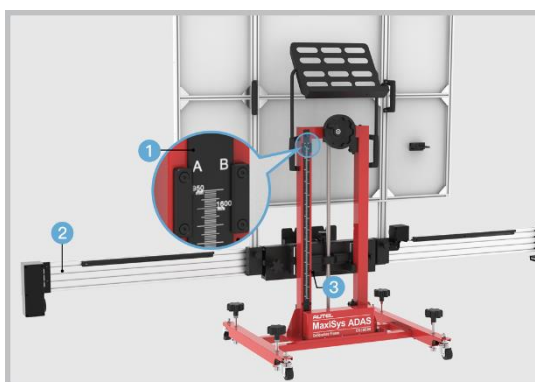

6. Measure the wheel housing-rim heights of every wheel. Input the heights on the tablet. Tap **OK**.

7. Follow the instructions on the tablet until the calibration is successful.

When the message displays that the calibration is successful, tap **OK**. The front camera calibration is now completed.

3.5 Around View Monitoring (AVM) System

This instruction example uses an Audi vehicle.

Calibration procedures can vary by vehicle. Please follow the instructions for your specific vehicle on your tablet.

3.5.1 Please select reason for calibration

1. Replaced the panoramic camera
2. Replaced the panoramic camera system control unit
3. Repaired the components that are equipped with panoramic camera or affect camera installation
4. Adjusted the chassis
5. Overlapped areas of images shot by panoramic cameras are dislocated
6. Adjusted the vehicle body height
7. Adjusted the position of panoramic camera on vehicle body.

3.5.2 Required Calibration Tools

- ✓ Pattern AUTEL-CSC0806/01
- ✓ Laser AUTEL-CSC0500/04
- ✓ Target Board (x2) AUTEL-CSC0804/01
- ✓ Target Board Holder (x2) AUTEL-CSC0804/02
- ✓ Tape Measure

3.5.3 Calibration Preparations

1. Park the vehicle on a level surface. Center the steering wheel and keep the front wheels of the vehicle in a straight-ahead position (If necessary, perform the wheel alignment first). Ensure there is ample room around the vehicle;

2. Extend the exterior rear view mirrors on both sides of the vehicle;
3. Ensure all camera lenses are clean. If needed, clean lenses with damp cloth;
4. Check the respective camera images on the central console display. Replace the camera if the image is affected due to camera damage. Check and correct the respective camera position if image is at an angle;
5. Ensure the vehicle's coolant and engine oil are topped off and the gas tank is full. The vehicle should not be carrying any additional load (such as passengers or cargo);
6. Attach the VCI to the vehicle and connect the diagnostic tool to the VCI (if the diagnostic tool and VCI are connected by a diagnostic cable, guide the cable through a window);
7. Apply the parking brake and close all doors, hood, and trunk;
8. Adjust the tire pressure to the recommended level;
9. Set the ride setting to "Comfort";
10. Set the chassis height to "Normal" and then set it to "Jack Mode" by selecting "Jack Mode" (the level adjustment function is turned off);
11. If needed, connect the vehicle to a battery maintainer to prevent battery discharge;
12. Turn on ignition;
13. Ensure no one is inside the vehicle during calibration;
14. To avoid recognition error, ensure there are no objects surrounding the calibration area;
15. Ensure the calibration area is well lit.

 **NOTE**

- Do not open or close doors during calibration.
 - Ensure the ignition is on during calibration.
-

3.5.4 Auxiliary Tool Positioning

➤ **To assemble the calibration tools**

1. Assemble two sets of calibration tools. Place the target board holder AUTEL-CSC0804/02 on a level surface.
2. Mount the target board AUTEL-CSC0804/01 onto the hook (1) on the top of the target board holder.

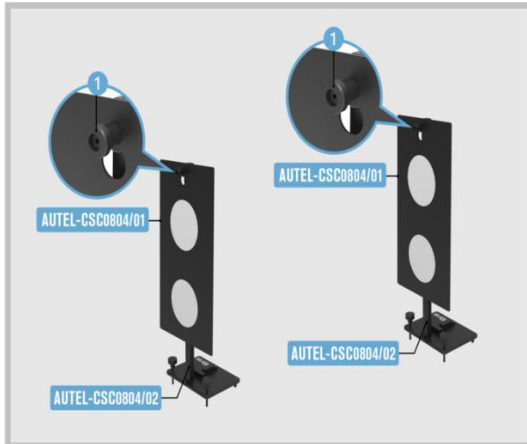

➤ **To position the auxiliary tools in front of the vehicle**

1. Lay the pattern AUTEL-CSC0806/01 directly in front of the vehicle, measure the distance ($B=4200$ mm (165.35 in)) between the center of the rear wheels and the marked line (1). Ensure the distances on both sides are the same.
2. Place the laser AUTEL-CSC0500/04 and turn on the laser. Align the marked line (2) on the back of the laser and laser beam (3) with the marked lines (4) and (5) on the pattern respectively.
3. Move the pattern AUTEL-CSC0806/01 left or right to aim the laser beam (3) at the center of the vehicle emblem. Turn off the laser and store it.

 **NOTE**

- Ensure the pattern AUTEL-CSC0806/01 is positioned correctly and that its surface lies flat and reflects no light.
 - Ensure the position of the laser does not change when moving the pattern.
-

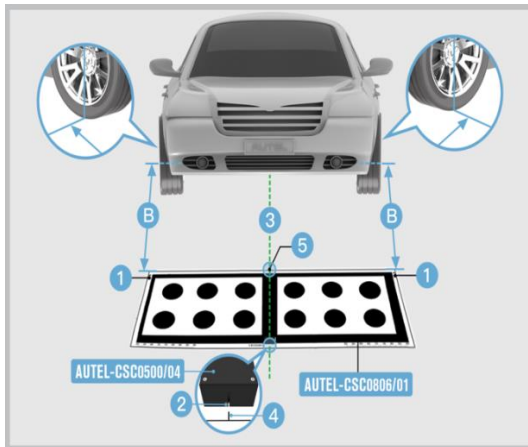

4. Position the two assembled calibration tools. Ensure the side (1) with marked line on the base of the target board holder aligns with the edge of the ruler (2) on the pattern.
5. Move the target board holder left or right to aim the marked line (3) at 775 on the ruler (2).
6. Rotate the bolts (4) and (5) so that the bubbles in the bubble levels (6) and (7) are centered.

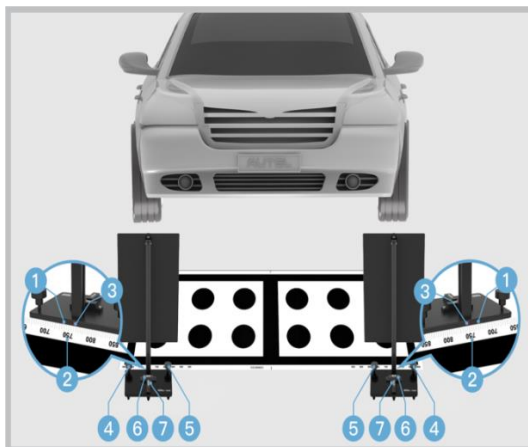

➤ **To position the auxiliary tools behind the vehicle**

1. Lay the pattern AUTEL-CSC0806/01 directly behind the vehicle. Measure the distance between the center of the rear wheels (B=1.47 m - 1.90 m (158 in – 75 in)) and the marked line (1). Ensure the distance on both sides are the same.
2. Position the laser AUTEL-CSC0500/04 and turn on the laser. Align the marked line (2) on the back of the laser and the laser beam (3) with the corresponding marked lines (4) and (5) on the pattern.
3. Move the pattern AUTEL-CSC0806/01 left or right to aim the laser beam (3) at the center of the vehicle emblem. Turn off the laser and store it.

NOTE

- Ensure the pattern AUTEL-CSC0806/01 is positioned correctly and that its surface lies flat and reflects no light.
- Ensure the position of the laser does not change when moving the pattern.

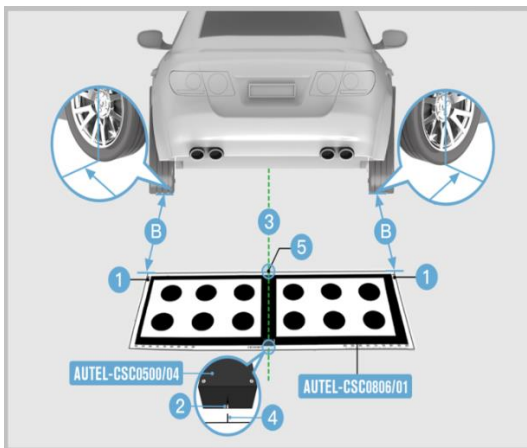

4. Place the two assembled calibration tools. Ensure the side (1) with marked line on the base of the target board holder attaches with the edge of the ruler (2) on the pattern.
5. Move the target board holder left or right to aim the marked line (3) at 775 on the ruler (2).
6. Rotate the bolts (4) and (5) so that the bubbles in the bubble levels (6) and (7) are centered.

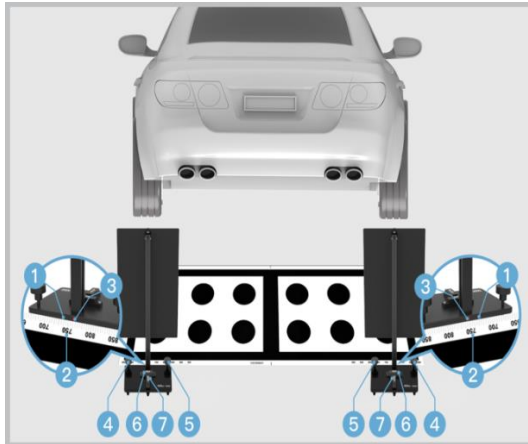

7. Measure the distance A (unit: mm) between marked line pattern (1) and the center of the rear wheel and enter it into the diagnostic tablet.

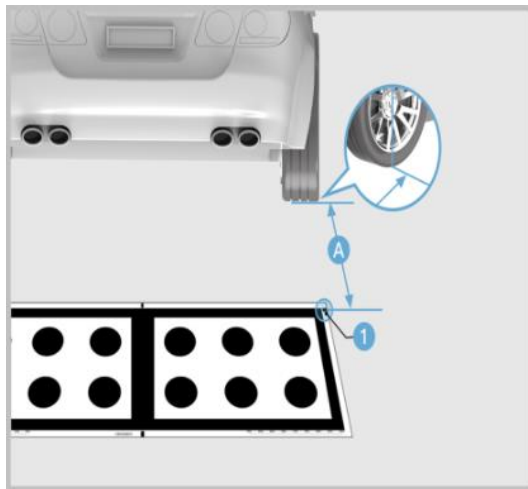

➤ **To position the auxiliary tools on the left side of the vehicle**

1. Lay the pattern AUTEL-CSC0806/01 on the left side of the vehicle (based on the driving direction of the vehicle). Ensure the black edge (1) aligns with the center of the front wheel.
2. Ensure that the edge (2) of the pattern parallels with the vehicle body, and the distance between the edges (2) and the front wheel B=150 mm – 200 mm (6.0 in – 7.8 in).

NOTE

Ensure the pattern AUTEL-CSC0806/01 is placed correctly so that the long side without scale is next to the vehicle and the surface lies flat and reflects no light.

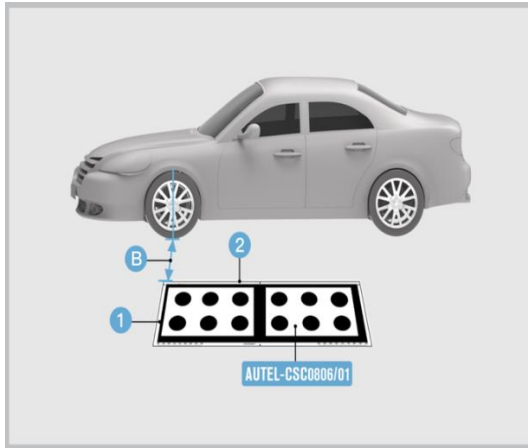

3. Place the two assembled calibration tools. Ensure the side (1) with marked line on the base of the target board holder attaches to the edge of the ruler (2) on the pattern.
4. Move the target board holder left or right to aim the marked line (3) at 775 on the ruler (2).
5. Rotate the bolts (4) and (5) so that the bubbles in the bubble levels (6) and (7) are centered.

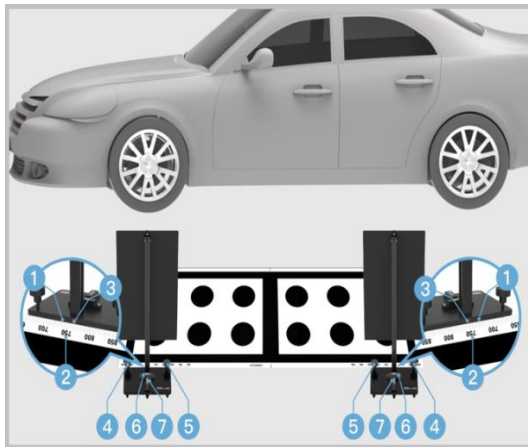

➤ **To position the auxiliary tools on the right side of the vehicle**

1. Lay the pattern AUTEL-CSC0806/01 on the right side of the vehicle (based on the driving direction of the vehicle). Ensure the black edge (1) aligns with the center of the front wheel.
2. Ensure that the edge (2) of the pattern parallels with the vehicle body, and the distance between the edges (2) and the front wheel B=150 mm – 200 mm (6.0 in – 7.8 in).

 **NOTE**

Ensure the pattern AUTEL-CSC0806/01 is placed correctly so that the long side without the scale is next to the vehicle and the surface lies flat and reflects no light.

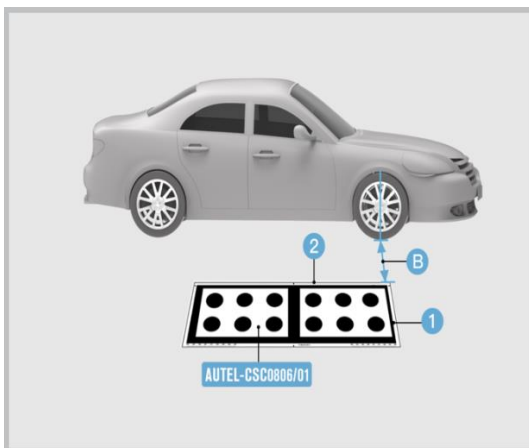

3. Place the two assembled calibration tools. Ensure the side (1) with the marked line on the base of the target board holder attaches to the edge of the ruler (2) on the pattern.
4. Move the target board holder left or right to aim the marked line (3) at 775 on the ruler (2).
5. Rotate the bolts (4) and (5) so that the bubbles in the bubble levels (6) and (7) are centered.

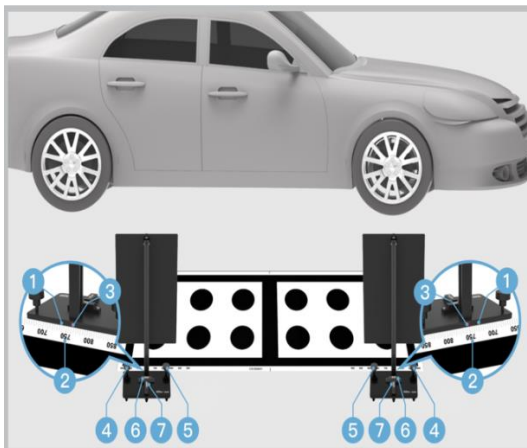

Follow the instructions on the tablet until the calibration is successful. When the message displays that the calibration is successful, tap **OK**. The Around View Monitoring system calibration is now completed.

4 Alignment Precheck Procedures

The MaxiSys diagnostic tablet can not only calibrate the camera and sensor, but also pre-check the four-wheel positioning parameters prior to the ADAS calibration. This chapter discusses tools needed and what preparatory measures are to be taken when the Precheck operation is required.

The IA800 system is designed with six high-resolution cameras and ADAS positioning software to deliver rapid yet precise frame centering and vehicle distancing. The procedures vary by vehicle make, model, and year. Please follow the step-by-step instructions for your specific vehicle on the MaxiSys tablet to complete this operation.

4.1 Alignment Precheck

This instruction example uses an Audi vehicle.

The procedures can vary by vehicle. Please follow the instructions for your specific vehicle on your tablet.

4.1.1 When Alignment Precheck is needed

Alignment Precheck must be performed under any of the following circumstances:

1. You suspect that the four-wheel alignment parameters are abnormal
2. The vehicle deviates
3. The vehicle steering wheel is not correct or the steering wheel shakes
4. Abnormal tire wear
5. You replaced parts that affect positioning parameters such as steering tie rods, etc.
6. Check before ADAS calibration

Please select the correct vehicle information such as the suspension, driving position, etc. prior to performing the measurement.

4.1.2 Required Tools

- ✓ Calibration Frame AUTEL-CSC0600
- ✓ Wheel Clamp AUTEL-CSC0500/07-LF
- ✓ Wheel Clamp AUTEL-CSC0500/07-RF
- ✓ Wheel Clamp AUTEL-CSC0500/07-LR
- ✓ Wheel Clamp AUTEL-CSC0500/07-RR
- ✓ Target AUTEL-CSC0500/09-LF
- ✓ Target AUTEL-CSC0500/09-RF
- ✓ Target AUTEL-CSC0500/09-LR
- ✓ Target AUTEL-CSC0500/09-RR
- ✓ Wheel Chock
- ✓ Steering Wheel Holder Stand Tool
- ✓ 24V Power Adapter

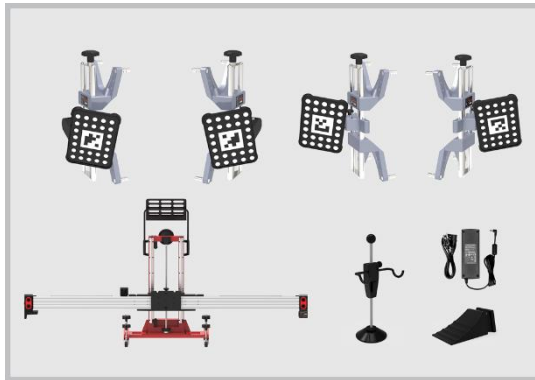

4.1.3 Vehicle Preparations

1. Park the vehicle on level ground, keep the front wheels of the vehicle in a straight-forward position, and ensure there is at least 1.5 m of space in front of the vehicle.
2. Place a wheel chock on the front and rear of the left- or right-rear wheel to prevent the vehicle from sliding.

3. Center the steering wheel, install the steering wheel holder stand tool, release the handbrake, and engage the neutral gear (gear N).
4. Keep the vehicle unloaded, check if the coolant and engine oil levels are topped off and the fuel tank is full.
5. Turn off all doors and exterior lighting.
6. Adjust the tire pressure to the specified level.
7. If the vehicle is equipped with air suspension, adjust to Standard mode (depending on the vehicle model) before performing the measurement.

4.1.4 Auxiliary Tool Positioning

➤ **To position the calibration frame**

1. Move the calibration frame AUTEL-CSC0600 to level ground in front of the vehicle. If the pattern board or the target board holder has been installed onto the crossbar, remove it first.
2. Rotate the fine tuning bolt (1) to align the red marked lines in point A.
3. Loosen the handle (2) on the crossbar, then rotate the fine tuning bolt (3) until the point B is aligned with the red marked line. Tighten the handle (Pos. 2) to secure the crossbar.
4. Align the pointer on the sliding plate with the red marked line at point C, and then tighten the bolt (4) to secure the sliding plate.

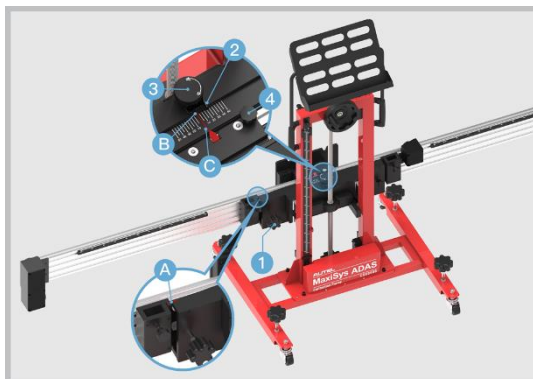

➤ **To center the laser at the front of the vehicle**

1. Keep the front wheels of the vehicle in a straight-forward position.
2. Place the calibration frame AUTEL-CSC0600 directly in front of the vehicle. Adjust the height of the crossbar so that it is roughly at the same height as the center of the front wheel.
3. Hold the handle on the calibration frame and slowly move the frame until the (horizontal) distance between the centers of both front wheels and the back of the crossbar are basically equal. Turn on the slide plate laser (1) and aim it at the front center of the vehicle.
4. Plug the included power cord into the power port (2) and turn on the power (3) of the camera kit.

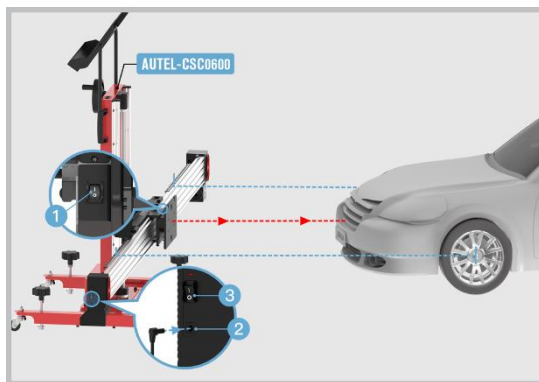

➤ **To install the wheel clamps**

1. Check the wheel clamp AUTEL-CSC0500/07 to ensure the four pawls (1) are equal in length.
2. Attach the four wheel clamps to their corresponding wheels and rotate the bolt (2) clockwise until the pawls (1) are tightly secured.

NOTE

Ensure wheel clamps are vertically installed on the hub, and the installation angle is within the range of -8° and 8° .

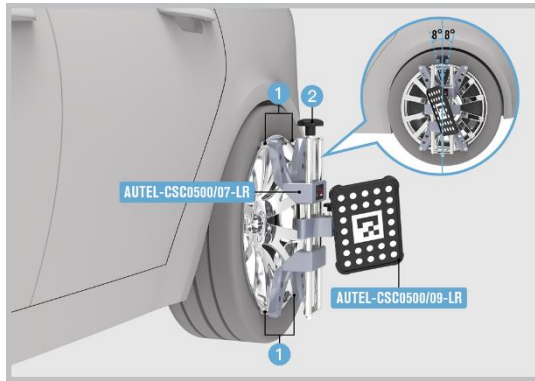

Follow the instructions displayed on the diagnostic tablet to perform the Alignment Precheck function.

5 Maintenance and Service

5.1 Maintenance Instructions

5.1.1 Target Maintenance

DO NOT use hard objects to strike or scratch the surface of the target, which may cause the target to be unidentifiable. Notice a dirt build-up, oil or grease can also cause target identification problems.

In the target pattern display screen, the following red icon appears on the target pattern, which means the target may need cleaning.



Red icon: Target not found.

When cleaning the target, it is not recommended to use shop towels or rags as the fibers retain grease, which will be deposited back on the surface of the target in a thin film as wiping continues.

Use a mild cleaning solution and soft paper towels to wipe off the surface of targets.

DO NOT hose down or submerge the targets in water, or spray cleaner directly on the target. This could damage the optical components. When cleaning, wipe the entire target completely.

5.1.2 Camera Maintenance

Keep hands and tools away from the camera lens area.

DO NOT attempt to clean the camera lens with standard window cleaner and a cloth, or by blowing on them with shop air. If cleaning ever becomes necessary, it should be done with special optical cleaning fluid and/or canned air.

5.2 Service Procedures

This section introduces information for technical support, repair service, and application for replacement or optional parts.

5.2.1 Technical Support

If you have any question or problem on product operations, please contact us.

Autel China Headquarters

- **Phone:** +86 (0755) 8614-7779 (Monday-Friday, 9AM-6PM Beijing Time)
- **Email:** support@autel.com
- **Address:** Floor 2, Caihong Keji Building, 36 Hi-tech North Six Road, Songpingshan Community, Xili Sub-district, Nanshan District, Shenzhen City, China
- **Web:** www.autel.com

Autel North America

- **Phone:** 1-855-288-3587 (Monday-Friday, 9AM-6PM Eastern Time)
- **Email:** ussupport@autel.com
- **Address:** 36 Harbor Park Drive, Port Washington, New York, USA 11050
- **Web:** www.autel.com/us

Autel Europe

- **Phone:** +49(0)89 540299608 (Monday-Friday, 9AM-6PM Berlin Time)
- **Email:** support.eu@autel.com
- **Address:** Landsberger Str. 408, 81241 München, Germany
- **Web:** www.autel.eu

Autel APAC

Japan:

- **Phone:** +81-045-548-6282
- **Email:** support.jp@autel.com
- **Address:** 6th Floor, Ari-nadoribiru 3-7-7, Shinyokohama, Kohoku-ku, Yokohama-shi, Kanagawa-ken, 222-0033 Japan
- **Web:** www.autel.com/jp

Australia:

- **Email:** ausupport@autel.com
- **Address:** Unit 5, 25 Veronica Street, Capalaba

Autel IMEA

- **Phone:** +971 585 002709 (in UAE)
- **Email:** imea-support@autel.com
- **Address:** 906-17, Preatoni Tower (Cluster L), Jumeirah Lakes Tower, DMCC, Dubai, UAE
- **Web:** www.autel.com

Autel Latin America

Mexico:

- **Phone:** +52 33 1001 7880 (Spanish in Mexico)
- **Email:** latsupport@autel.com
- **Address:** Avenida Americas 1905, 6B, Colonia Aldrete, Guadalajara, Jalisco, Mexico

Brazil:

- **Email:** brsupport@autel.com
- **Address:** Avenida José de Souza Campos n° 900, sala 32 Nova Campinas Campinas – SP, Brazil
- **Web:** www.autel.com/br

5.2.2 Repair Service

If it is necessary to send back your device for repair, please download and fill out the repair service form from www.autel.com. The following information must be included:

- Contact name
- Return address
- Telephone number
- Product name
- Complete description of the problem
- Proof-of-purchase for warranty repairs
- Preferred method of payment for non-warranty repairs

 **NOTE**

For non-warranty repairs, payment can be made with Visa, Master Card, or with approved credit terms.

Send the equipment to your local agent, or to the address below:

Floor 2, Caihong Keji Building, 36 Hi-tech North Six Road, Songpingshan Community, Xili Sub-district, Nanshan District, Shenzhen City, China

5.2.3 Other Services

You can purchase the accessories directly from authorized tool suppliers of Autel, or your local distributor or agent.

Your purchase order should include the following information:

- Contact information
- Product or part name
- Item description
- Purchase quantity

6 Compliance Information

FCC Compliance

This device complies with Part 15 of the FCC rules. Operation is subject to the following two conditions:

1. This device may not cause harmful interference, and
2. This device must accept any interference received, including interference that may cause undesired operation.

WARNING

Changes or modifications not expressly approved by the party responsible for compliance could void the user's authority to operate the equipment.

This equipment has been tested and found to comply with the limits for a Class B digital device, pursuant to Part 15 of the FCC Rules. These limits are designed to provide reasonable protection against harmful interference in a residential installation.

This equipment generates uses and can radiate radio frequency energy and, if not installed and used in accordance with the instructions, may cause harmful interference to radio communications. However, there is no guarantee that interference will not occur in a particular installation. If this equipment does cause harmful interference to radio or television reception, which can be determined by turning the equipment off and on, the user is encouraged to try to correct the interference by one or more of the following measures:

- Reorient or relocate the receiving antenna.
- Increase the separation between the equipment and receiver.
- Connect the equipment into an outlet on a circuit different from that to which the receiver is connected.
- Consult the dealer or an experienced radio/TV technician for help.

FCC Radiation Exposure Statement

This equipment complies with FCC radiation exposure limits set forth for an uncontrolled environment. This equipment should be installed and operated with minimum distance 20cm between the radiator & your body.

RoHS COMPLIANCE

This device is declared to be in compliance with the European RoHS Directives:

Directive 2011/65/EU and Directive (EU) 2015/863.

IEC62321.

CE COMPLIANCE

This product is declared to conform to the essential requirements of the following Directives and carries the CE mark accordingly:

Directive 2014/53/EU

EMC: ETSIEN301489-1 V2.2.3 (2019-11) and ETSIEN301489-17 V3.1.1 (2017-02)

Safety: EN62368-1: 2014+A11: 2017

Health: EN62311: 2008

RF WARNING STATEMENT

The device has been evaluated to meet general RF exposure requirement. The device can be used in portable exposure condition without restriction.

RF: ETSIEN300328 V2.2.2 (2019-07), ETSIEN 300440V2.2.1 (2018-07), and ETSIEN 301893V2.1.1 (2017-05)

AUTEL[®]

Autel Intelligent Technology Corp., Ltd.

www.autel.com